

No	Part #	Description	Application	Qty Req	Price Each
1	ALH1893	Instrument panel (U)		1	114.95
2	ALH865	Defroster nozzle (U)		2	7.26
3	ALH1885	Door, glovebox		1	NCA
4	ALH1896	Lock w/key		1	NCA
5	ALH1897	Bumper, rubber		2	3.58
6	ALH2497	Glovebox		1	36.00
7	14A9443	Ashtray		1	NCA
8	14A9438	Brace, RH (U)		1	7.26
9	14A9437	Brace, LH (U)		1	7.26
10	11G9145	Speedometer, MPH		1	107.69
	11G9147	Speedometer, KPH		1	83.49
11	17H668	Gasket		1	7.57
12	27H1296	Clamp		2	4.84
13	17H1304	Nut		2	3.45
14	3H2822	Fuel gauge, instrument panel		1	38.42
15	17H1782	Cable, speedometer	-E11000	1	72.42
	1H9047	Cable, speedometer	E11001-	1	31.16
16	RFN405	Grommet		1	5.27
17	3H2765	Signal indicator assy		1	26.57
18	2H4732	Bulb, screw base		7	1.88

No	Part #	Description	Application	Qty Req	Price Each
19	1G2596	Courtesy light assy		1	19.06
20	811 2128	Cigar lighter assy	-E34076	1	51.43
	11G9133	Cigar lighter assy	E34077-	1	51.43

A faulty or inoperative fuel gauge is almost never due to the dash unit. See tank units on page 10.

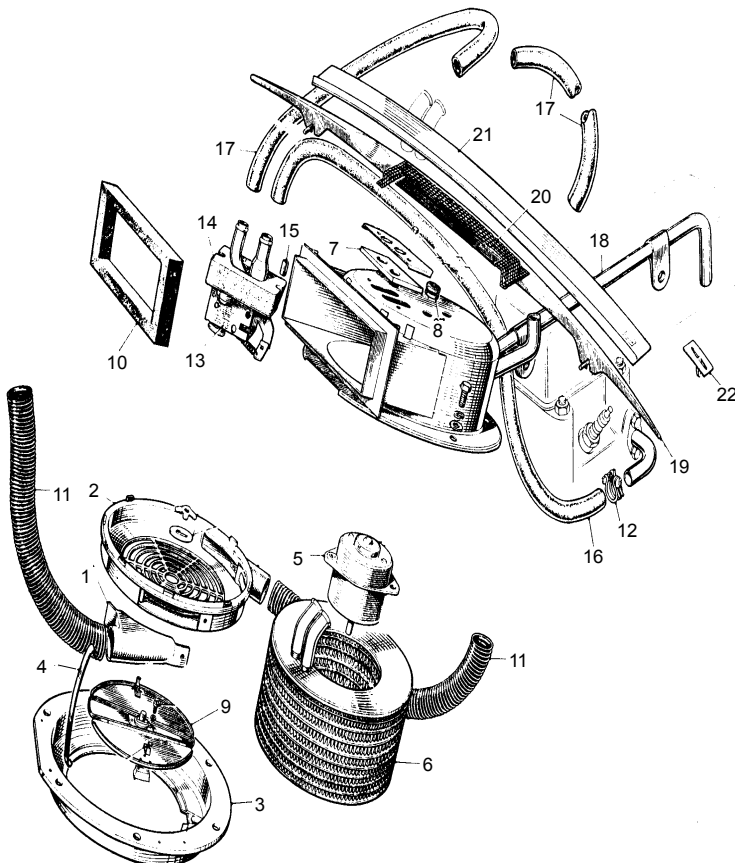

No	Part #	Description	Application	Qty Req	Price Each
	14A9400	Heater assy (X65)		1	223.85
	CP302	ID plate, heater		1	6.48
1	27H1226	Defroster nozzle (U)		2	10.89
2	27H1239	Front cover (U)		1	19.36
3	27H1225	Shroud, rubber		1	120.70
4	27H596	Clip (U)		3	8.17
5	17H1487	Motor (X20)		1	84.10
6	27H1240	Heater core		1	NCA
7	27H1229	Seal		1	4.79
8	27H1232	Grommet		3	3.33
9	27H1237	Door assy (U)		1	19.36
10	14A9418	Gasket		1	22.69
11	14A9405	Defroster duct		2	15.43
12	8G518	Clamp		7	3.21
13	2A9007	Control valve (X35)		1	120.70
14	3H2827	Seal		1	9.38
15	3H2828	Spacer		2	2.73
16	1G2921	Hose, elbow/valve		1	7.08
17	1G2268	Hose, valve/heater & heater/pipe		2	
6.00					
18	1G2918	Return pipe, copper (U)		1	38.72
19	ALH868	Cowl vent (U)		1	151.25
20	ALH1479	Screen		1	17.85
21	ALH1477	Weatherstrip, cowl		1	15.43
22	ALA4468	Clip		8	1.21